

Oxford Semiconductors

1394 TA

13th October 2008

Munich

Content

- Corporate Overview
- Benefits of 1394B over 1394A?
- Benefits of 1394 over USB?
- 1394 Storage Systems:
 - Oxford DAS Solutions
 - RAID systems
 - 936 family
- Questions/comments

Corporate Overview

- Founded 1992
- 120 Employees
- Core Technology:
 - Storage Systems
- Global operations
- Proven record of product innovation
 - First 1394B storage bridge
 - First 1394 to SATA family of bridges
 - First 1394 controller with hardware RAID
 - First 1394 controllers with real-time hardware encryption
 - Industry leading performance



The Oxford Solution

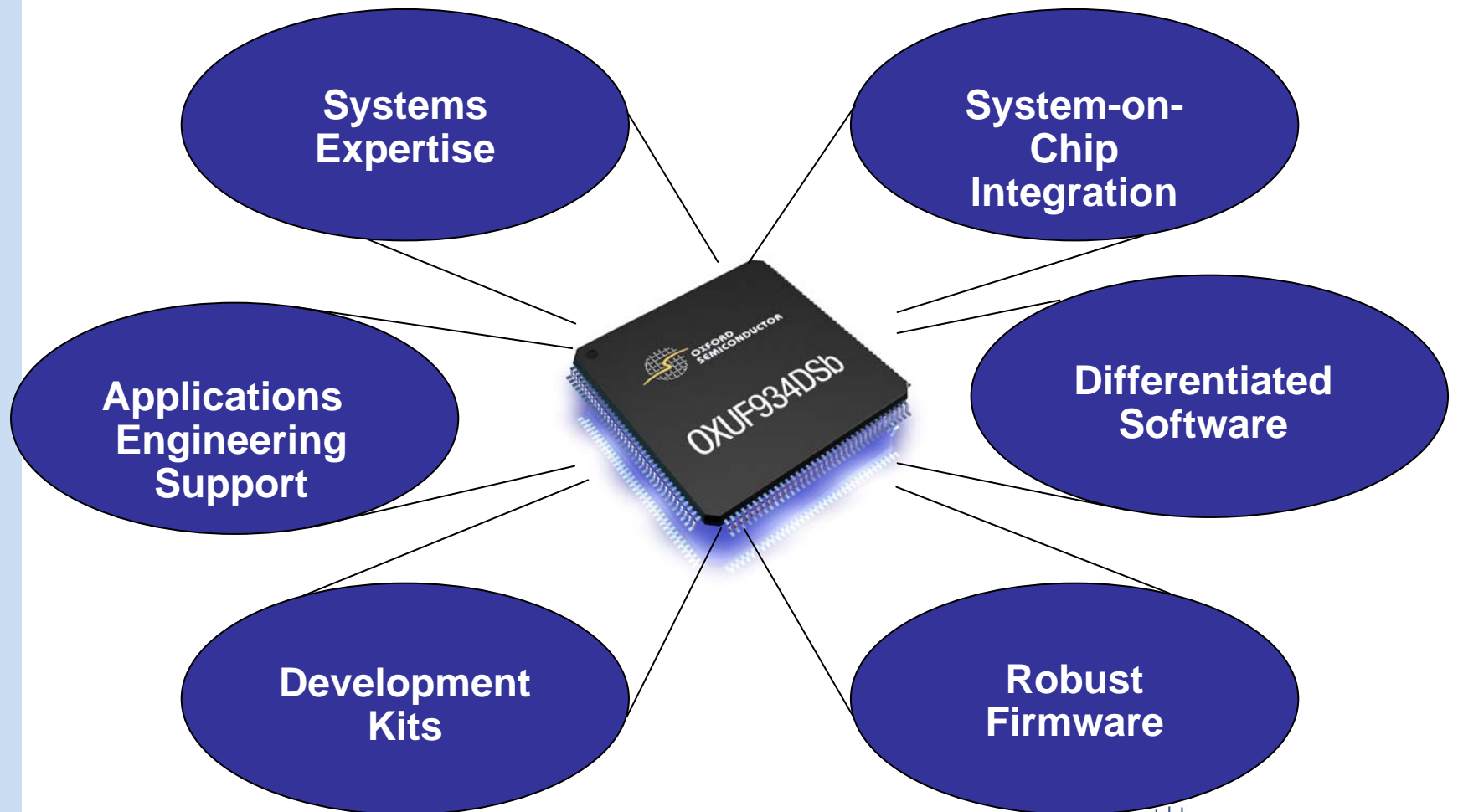

Content

- Corporate Overview
- Benefits of 1394B over 1394A?
- Benefits of 1394 over USB?
- 1394 Storage Systems:
 - Oxford DAS Solutions
 - RAID systems
 - 936 family
- Questions/comments

FW400 – Oxford Performance

Oxford architecture saturates 1394A

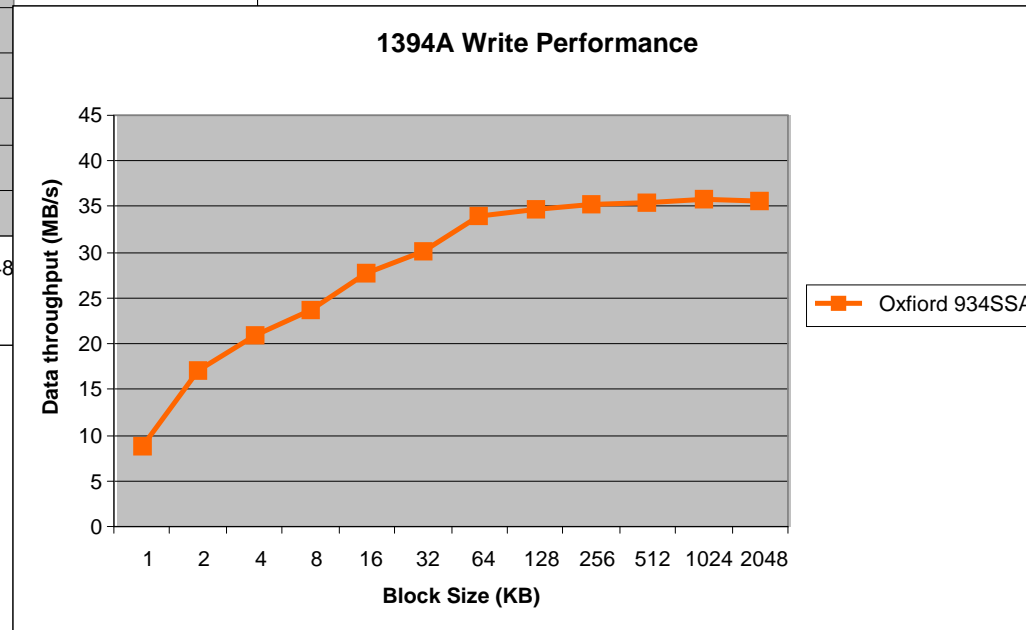
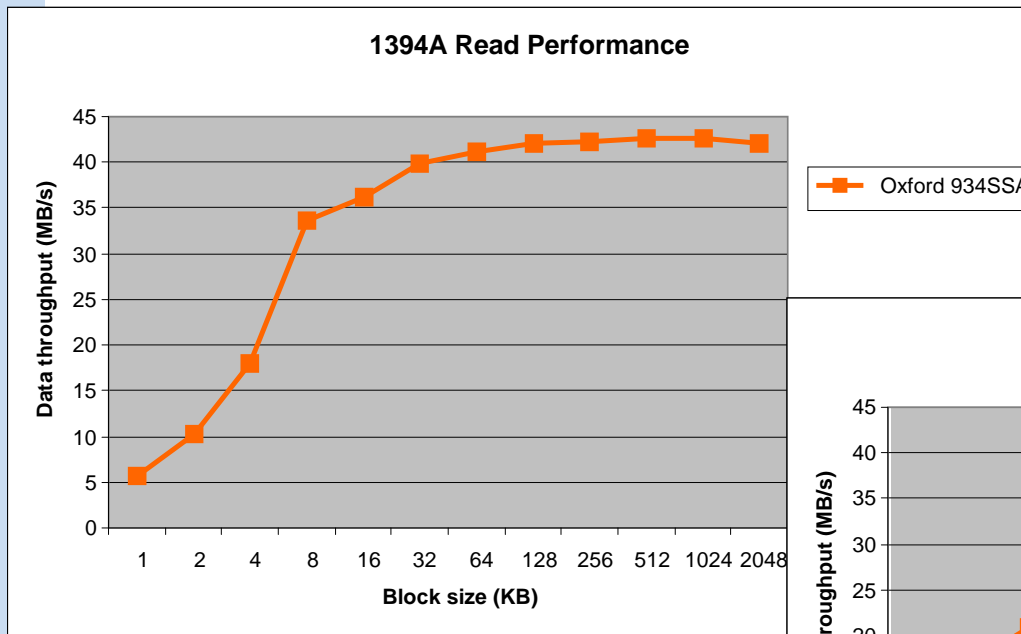

Oxford vs Nearest Competition FW800

Oxford architecture saturates 1394B

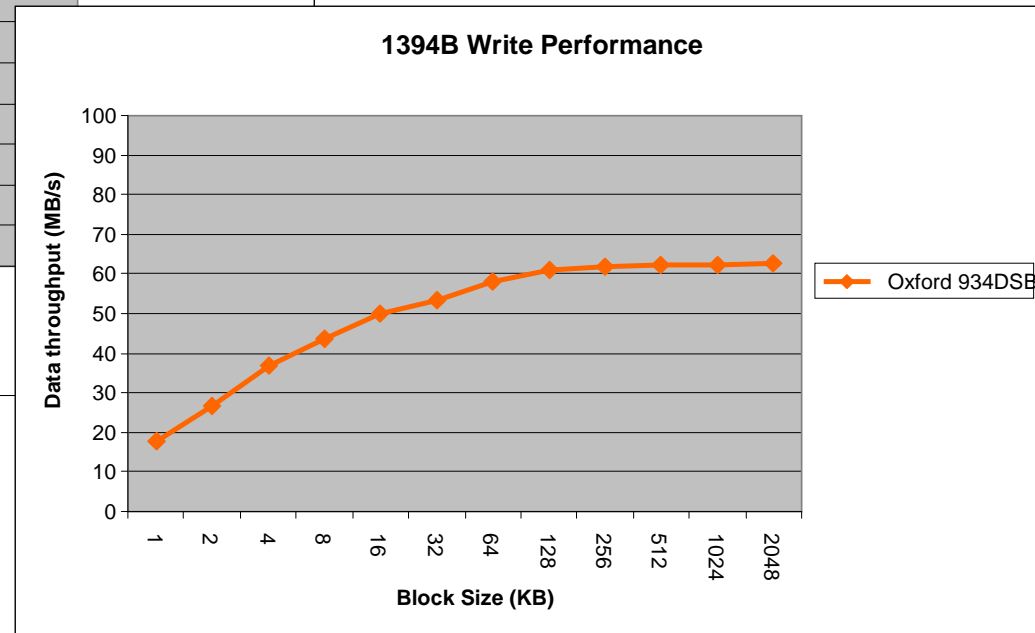
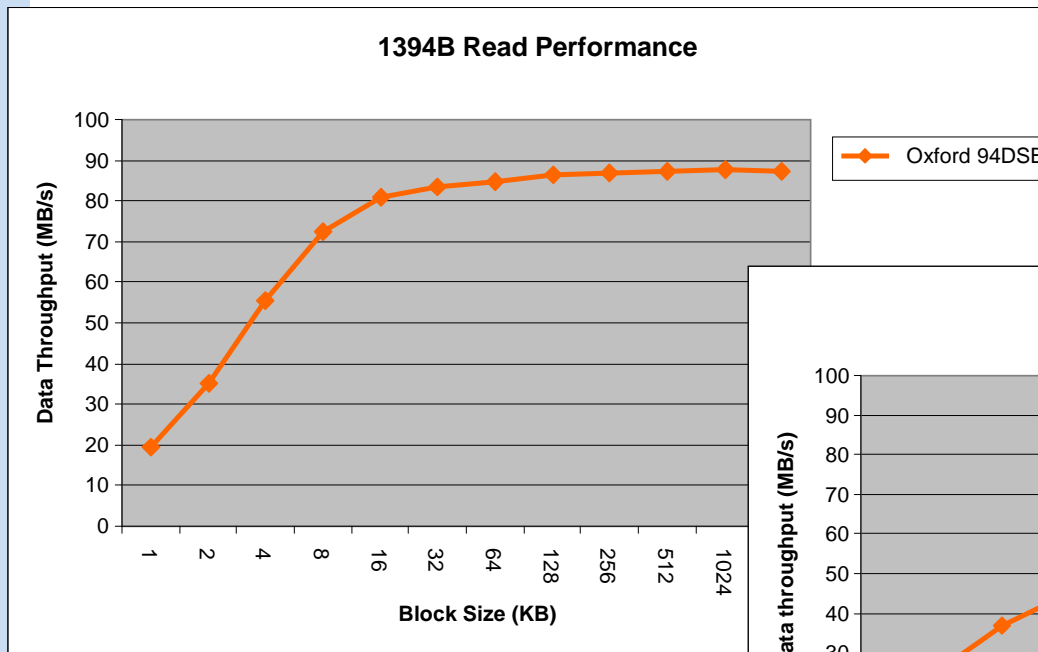

Content

- Corporate Overview
- Benefits of 1394B over 1394A?
- **Benefits of 1394 over USB?**
- **1394 Storage Systems:**
 - Oxford DAS Solutions
 - RAID systems
 - 936 family
- Questions/comments

Data Rate – 1394 versus USB 2.0

- **Headline Rata rates**

- USB2.0 480 Mbits/s
- 1394A (aka FireWire400) 400 Mbits/s
- 1394B (aka FireWire800) 800 Mbits/s

- **BUT**

- Headline data rates are deceiving and hide the actual performance of systems
- USB uses a Master/Slave topology
- USB Host controllers have low efficiencies and so low effective data rates
- 1394 uses Initiator/Target topology

Bus Efficiency – 1394 versus USB 2.0

	Headline (Mbps)	Actual Read	Actual Write	Efficiency (Average)
USB2.0	480	264	208	49%
1394A	400	332	264	75%
1394B	800	712	496	76%

- Even though USB2.0 has a higher headline data rate than 1394A, in reality it delivers much lower performance due to poor efficiency

Why choose 1394 ?

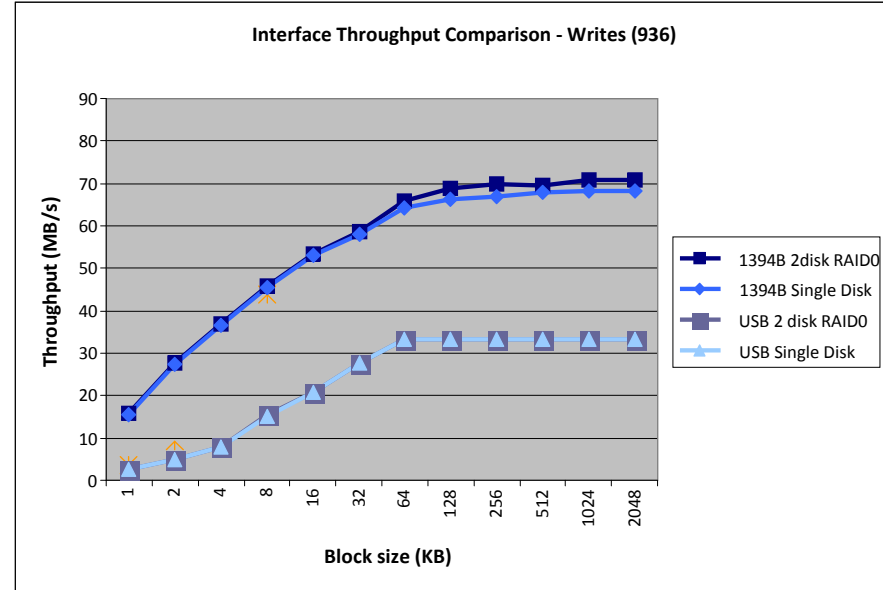
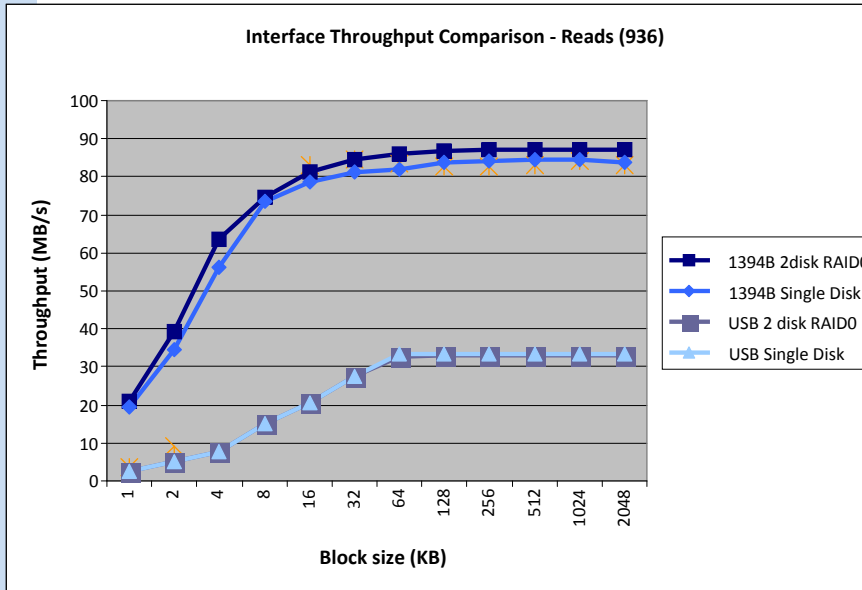

- Improvements in hard drive performance means that *even* for Single Disc systems, USB and FW400 now become the bottlenecks. FW800 has the bandwidth to meet the current maximum hard drive performance.

Oxford Performance with 1394B

1394B Read Performance

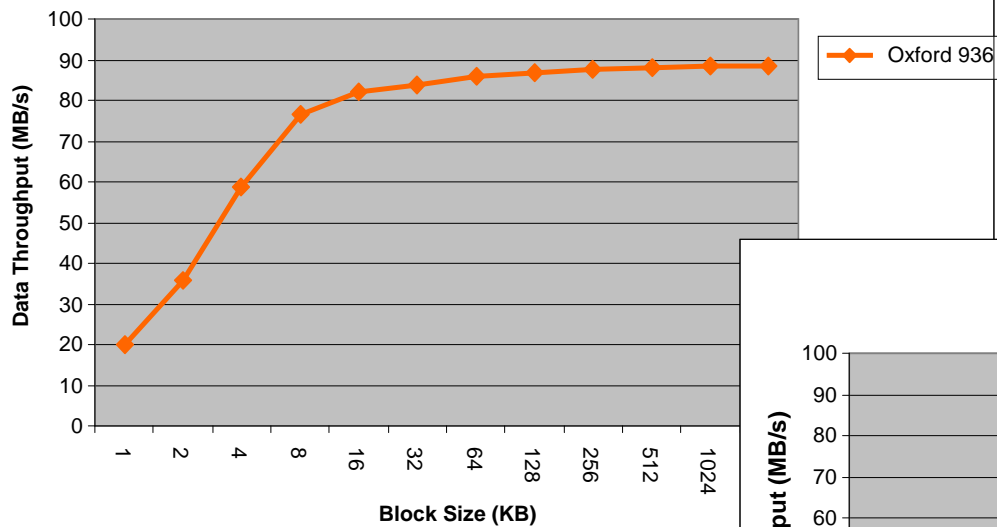

1394B Write Performance

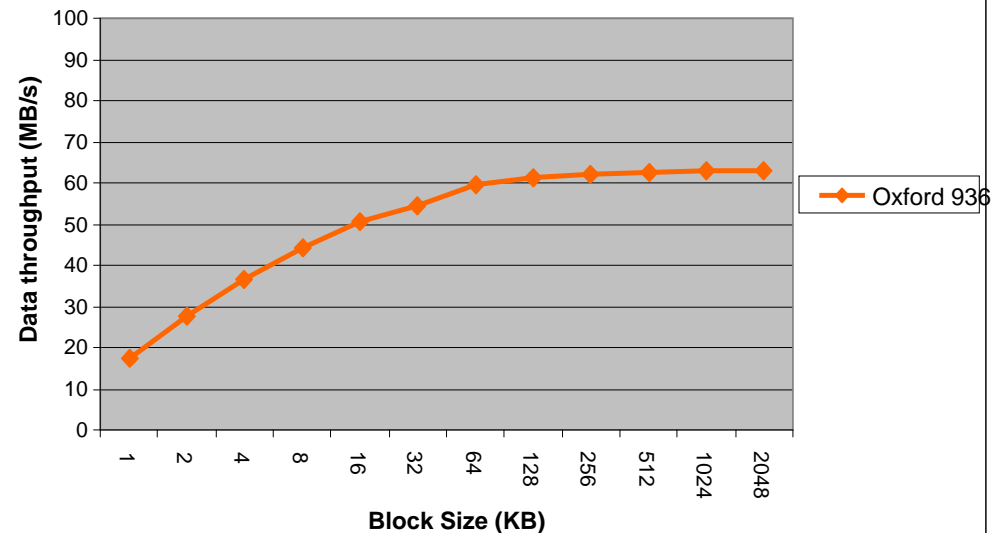

1394B to SATA

CPU Loading – 1394 vs USB 2.0

FireWire

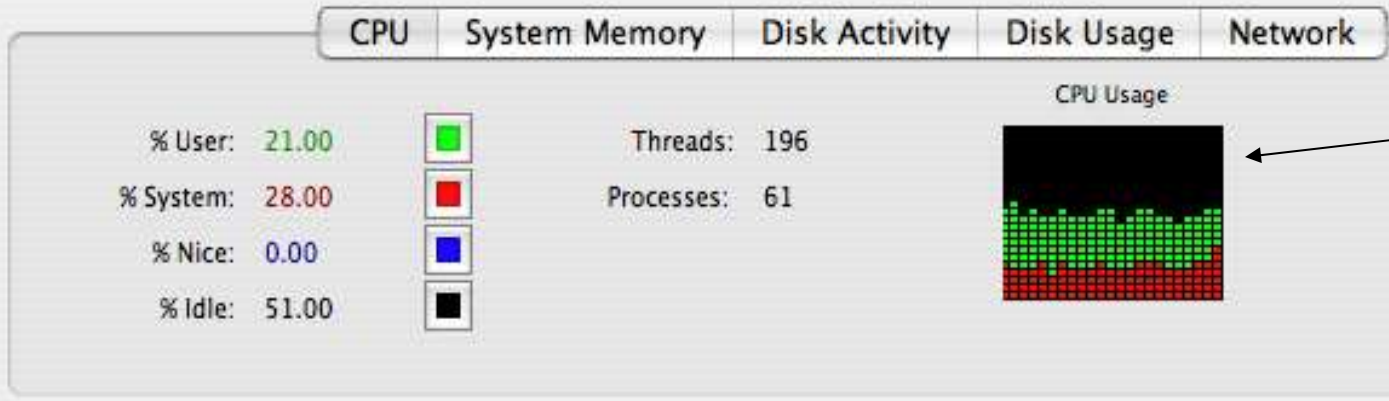

USB2.0 has bigger average CPU loading and larger variation in loading

USB2.0

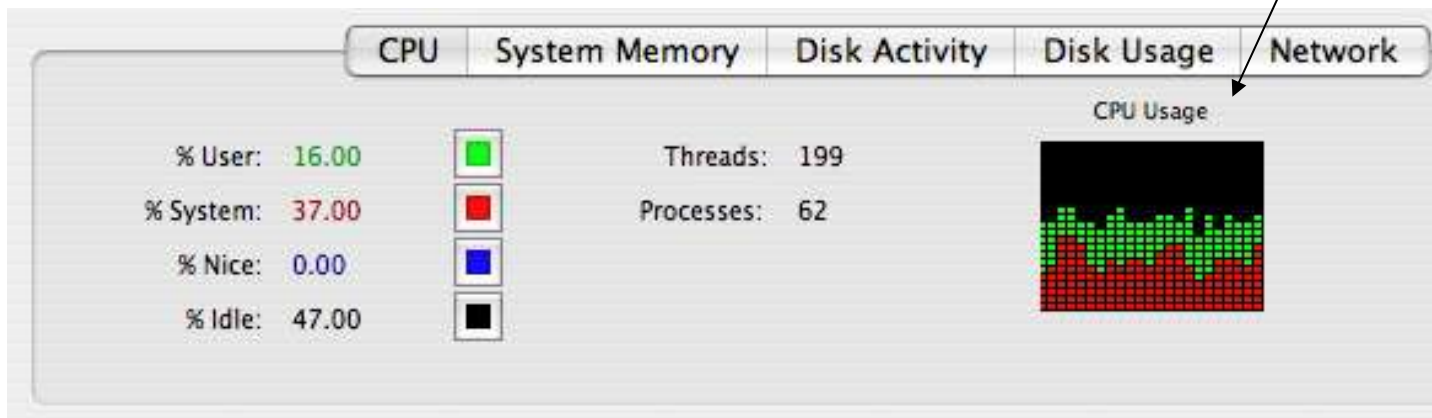

Other Comparison

	1394	USB2.0	eSATA
Bus Powered	<u>8V-27V@1.5A</u> (Typ: 12V@1.5A)	<u>5V@0.5A*</u>	None
Cable Length	4.5m-100m	3m - 5m	2m
Application	Various	Various	Data Transfer Only

* USB Bus Power will typically not be able to drive a 2.5" hard disk. Suppliers usually provide twin USB cables to support 2.5" bus powered hard drives

Content

- Corporate Overview
- Benefits of 1394B over 1394A?
- Benefits of 1394 over USB?
- **1394 Storage Systems:**
 - Oxford DAS Solutions
 - RAID systems
 - 936 family
- Questions/comments

OXUF934SSA

FW400/USB to SATA bridge

- Support for bus-powered, portable applications
- Auto-power feature tracks host status Support for external flash
 - Enabling customisation & differentiation
- I2C interface
- Support for USB HID
- 12 GPIOs (max)
 - Including HID button and HDD activity
- SATA II compliant
- LQFP128 pin package
 - 14*14mm

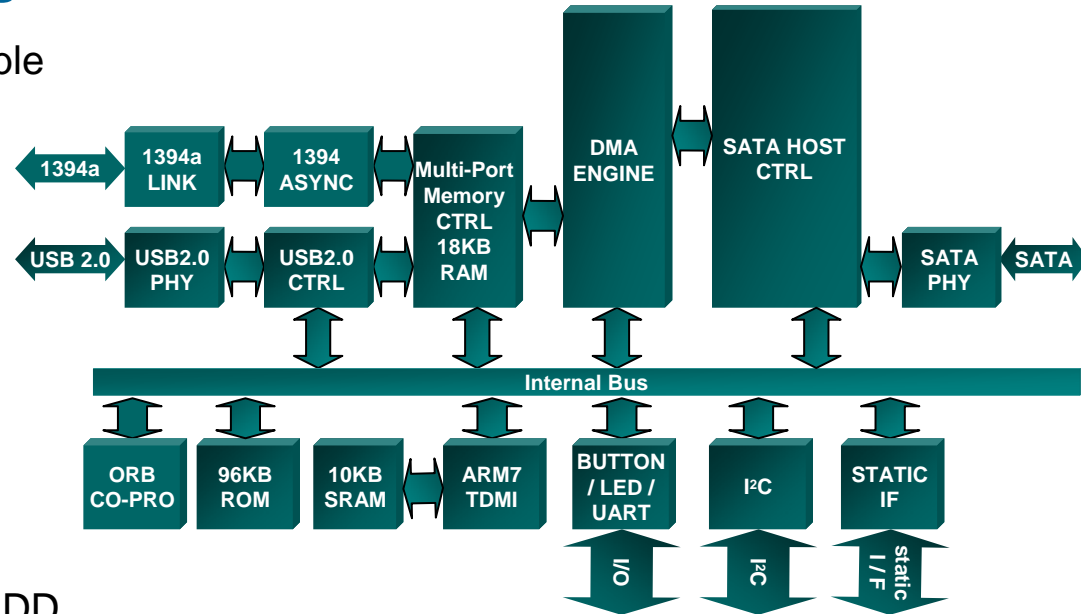

Content

- Corporate Overview
- Benefits of 1394B over 1394A?
- Benefits of 1394 over USB?
- 1394 Storage Systems:
 - Oxford DAS Solutions
 - RAID systems
 - 936 family
- Questions/comments

Oxford 93x RAID Portfolio

- Portfolio of RAID devices is expanded with the 93x series to offer single chip solutions for 2-disk and 4-disk RAID systems
 - 936QSE is a highly integrated device for 4-disk systems
 - 936DS and 936DSE are optimised for 2-disk systems
- Best in class performance across all interfaces
- Hardware acceleration for fastest possible 'online rebuilds'
 - Rebuild rates up to hard drive transfer rate (typically >60MB/s)
 - Supports load balancing with host activity
 - End user can continue to use system while rebuild ongoing
- Easy to configure
 - RAID level can be configured using hardware switches or via user interface

System Integration

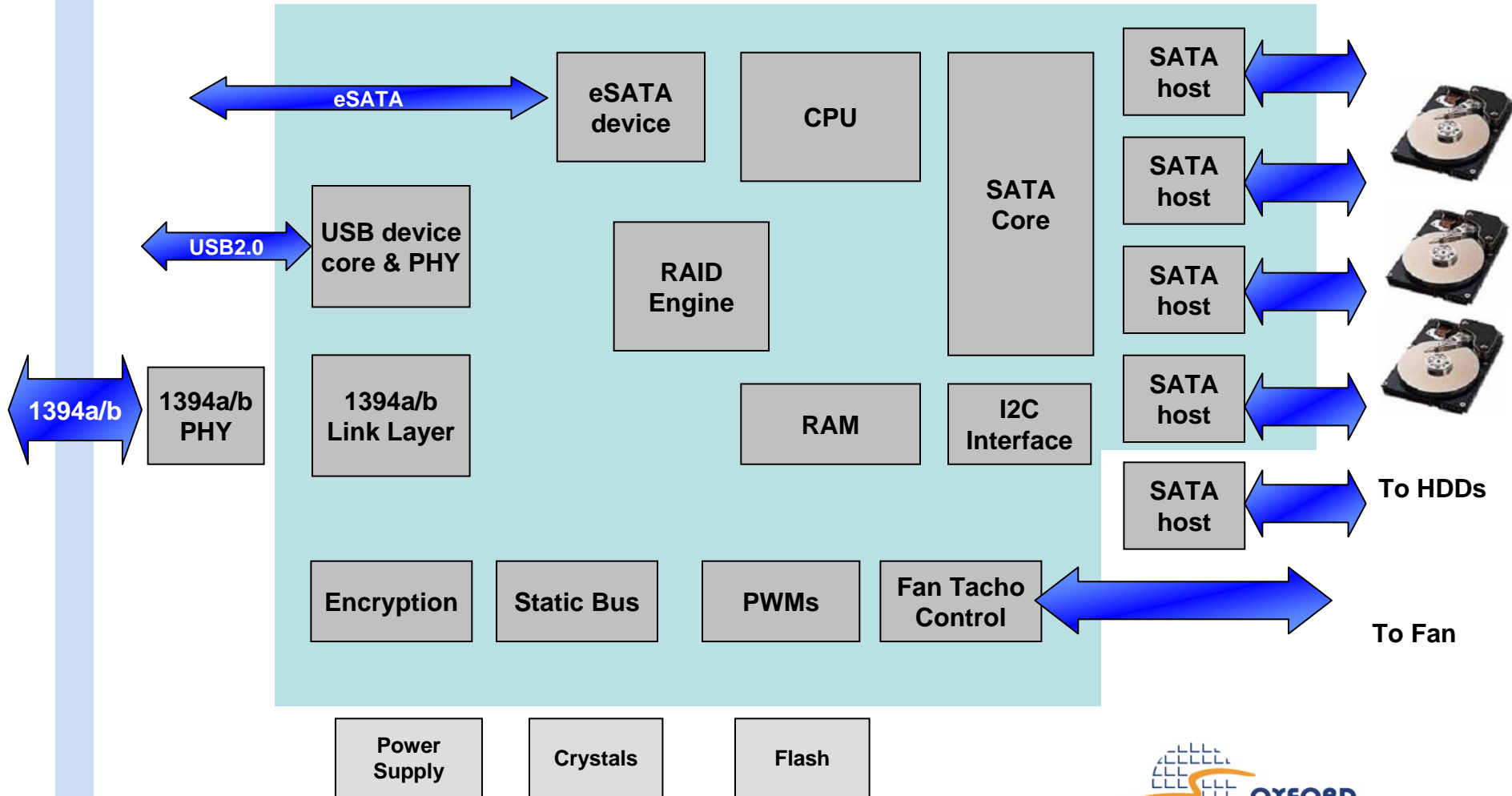

936 Performance – Dual disk

936 Family of RAID controllers saturates 1394B in Dual Disk Stripe (RAID 0)

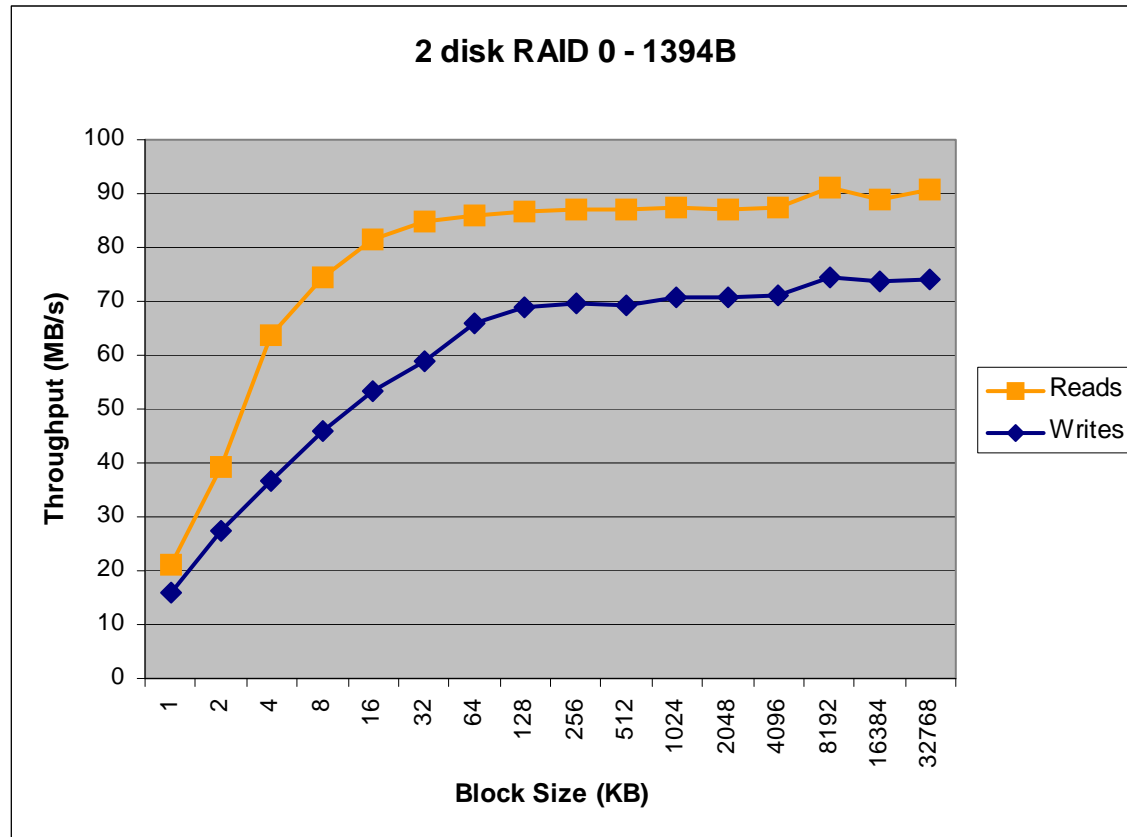

Oxford Delivers the Complete Package

- Complete reference systems for rapid product development
 - Demo PCB and reference schematics
 - Robust system software stress tested by Oxford
 - Supplied with full source code and HTML documentation
- Example RAID & encryption configuration tool
 - Building block for a host application which allows end users to select RAID level
- Extensive documentation including
 - Software Guides, Hardware Reference Manuals, Application Notes, etc
- Comprehensive tool chain and SDK for rapid product customisation
 - Industry standard GNU GCC v3.4.3 cross compiler
 - Debug via JTAG or UART
 - Programming and production utilities

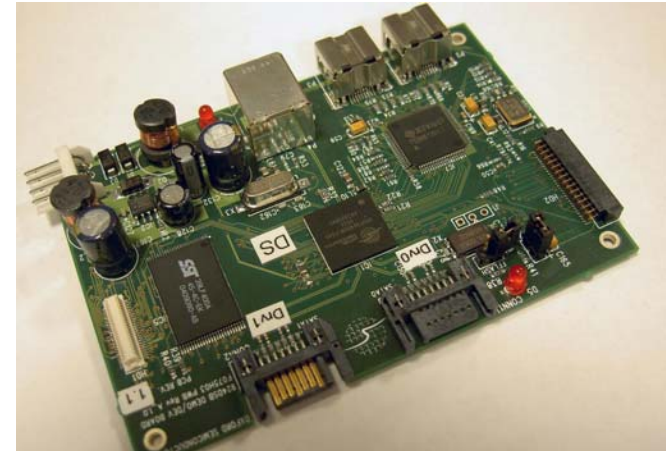

Thank You

For further information please contact:-

Malkit Jhitta

EMEA Sales Director

malkit.jhitta@oxsemi.com

Paul Baron

**Field Applications Engineer
EMEA**

paul.baron@oxsemi.com

Don Harwood

Head Of Technology

don.harwood@oxsemi.com